

LPS 350

350 Watts

LPS 350 Series

Total Power	350 Watts
Input Voltages	85 - 264 VAC 120 - 370 VDC
# of Outputs	Single



SPECIAL FEATURES

- Active power factor correction
- IEC EN61000-3-2 compliance
- Remote sense
- Power fail and remote inhibit
- Single wire current sharing
- Built-in EMI filter
- Low output ripple
- Supervisory output 5 V and 12 V
- Overvoltage protection
- Overload protection
- Thermal overload protection
- DC power good
- Cover -C
- Optional with fan cover -CF
- Optional end-mounted fan - CEF

ENVIRONMENTAL

Operating temperature: 0° to 50°C ambient derate each output at 2.5% per degree from 50° to 70°C

Electromagnetic susceptibility: Designed to meet EN61000-4, -2, -3, -4, -5, -6, Level 3

Humidity: Operating; non-condensing 5% to 95%

Vibration: Three orthogonal axes, sweep at 1 oct/min, 5 min. dwell at four major resonances 0.7 G peak 5 Hz to 500 Hz, operational

Storage temperature: -40° to 85°C

Temperature coefficient: ±.04% per °C

MTBF demonstrated: >550,000 hours at full load and 25°C ambient conditions

ELECTRICAL SPECIFICATIONS

Input

Input range	85-264 VAC; 120-370 VDC
Frequency	47-440 Hz
Inrush current	38 A max., cold start @ 25°C
Efficiency	75% typical at full load
EMI filter	FCC Class B conducted and radiated CISPR 22 Class B conducted and radiated EN55022 Class B conducted and radiated VDE 0878 PT3 Class B conducted and radiated.
Power factor	0.99 typical
Safety ground leakage current	<0.5 mA @ 50/60 Hz, 264 VAC input

Output

Maximum power	With cover: 350 W with 30 CFM forced air, (-C) (-CF) (-CEF)
Minimum load	No minimum load required
Adjustment range	2:1 wide ratio
Supervisory outputs	5 V @ 500 mA regulated, 12 V @ 150 mA x2
Hold-up time	20 ms @ 350 W load, 115 VAC nominal line at factory voltage setting
Overload protection	Short circuit protection on all outputs. Case overload protected @ 110-145% above peak rating
Overvoltage protection	5 V output: 5.7-6.7 VDC. Other outputs 10% to 25% above nominal output
Remote sense	Compensates for 0.5 V lead drop min. Will operate without remote sense connected. Reverse connection protected.

Logic Control

Power failure	TTL logic signal goes high 50-150 msec after 5 V output. It goes low at least 4 msec before loss of regulation
Remote on/off	Requires an external contact (N.O or N.C) to inhibit outputs
DC OK	TTL logic goes high 50-150 msec after the output. It goes low when there is loss of regulation.

SAFETY

VDE	0805/EN60950 (IEC950)	21310-3336-0001
UL	UL1950	E186249
CSA	CSA 22.2-234 Level 5	LR109492C
NEMKO	EN 60950/EMKO-TUE (74-sec) 203	P98102115
BABT	EN60950/BS7002	608857, 608858, 609097
CB	Certificate and report	5734, 6280, 6281
CE	Mark (LVD)	

ORDERING INFORMATION

Model Number	Output Voltage	Minimum Load	Maximum Load with 30 CFM Forced Air	Peak Load ¹	Regulation ²	Ripple P/P (PARD) ³
LPS352-C	5 V (3-6 V)	0 A	70 A	80 A	±2%	50 mV
LPS353-C	12 V (6-12 V)	0 A	29.2 A	33 A	±2%	120 mV
LPS354-C	15 V (12-24 V)	0 A	23.3 A	26 A	±2%	150 mV
LPS355-C	24 V (24-48 V)	0 A	14.6 A	16 A	±2%	240 mV

1. Peak current lasting <30 seconds with a maximum 10% duty cycle.
2. At 25°C including initial tolerance, line voltage, load currents and output voltages adjusted to factory settings.
3. Peak-to-peak with 20 MHz bandwidth and 10 µF in parallel with a 0.1 µF capacitor at rated line voltage and load ranges.
4. If optional CF or CEF fans are not used, 30CFM forced air cooling needs to be provided and is required through the length of the power supply. Not convection rated.
5. Output voltage adjustment requires a 1A load.

Note: -CF suffix added to the model number indicates cover with yop fan;
-CEF suffix added to model number indicates end-mounted fan chassis.

DRAWING

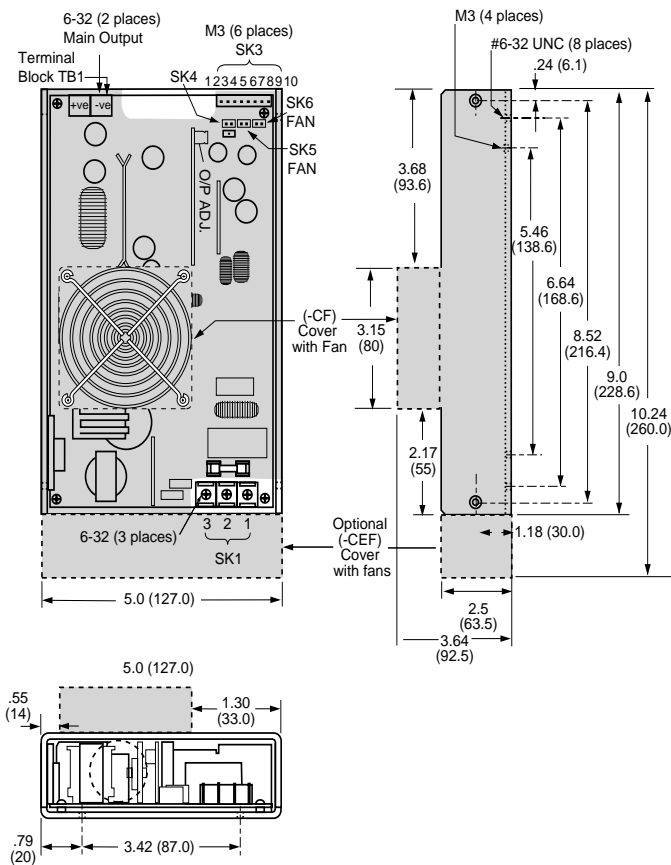

PIN ASSIGNMENTS

Connector

SK1	PIN 1	Neutral
	PIN 2	Line
	PIN 3	Ground

TB1		±
-----	--	---

SK3	PIN 1	N/C
	PIN 2	N/C
	PIN 3	+ Sense
	PIN 4	- Sense
	PIN 5	POK
	PIN 6	C.Share
	PIN 7	DC-OK
	PIN 8	Inhibit (N.O.)
	PIN 9	Inhibit (N.C.)
	PIN 10	COM

SK4	PIN 1	+ 5 V aux (5 V @ 100 mA)
	PIN 2	- Common

SK5	PIN 1	+ Fan 1 (12 V @ 150 mA)
	PIN 2	- Common

SK6	PIN 1	+ Fan 2 (12 V @ 150 mA)
	PIN 2	- Common

MATING CONNECTORS

SK3	Molex 22-01-1104 PINS:08-70-0057
-----	-------------------------------------

SK4	Molex 22-01-3027 PINS: 08-50-0114
-----	--------------------------------------

SK5	Molex 22-01-3027 PINS: 08-50-0114
-----	--------------------------------------

SK6	Molex 22-01-3027
-----	------------------

NOTES

1. Specifications subject to change without notice.
2. All dimensions in inches (mm), tolerance is ±.02".
3. Specifications are at factory settings
4. To enable normally closed Remote Inhibit, cut jumper J1.
5. Mounting maximum insertion depth is 0.12".
6. Warranty: 1 year
7. Weight: 3.6 lb. / 1.64 kg.